

L430
Self Latch Smart Lock
PL701, PL702

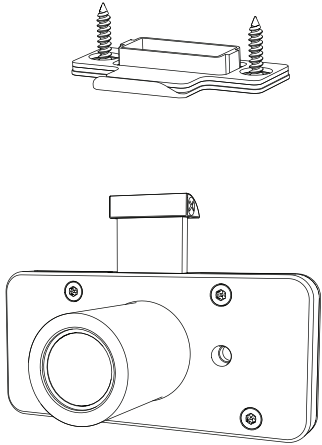

Non-Recessed Installation

Refer to Page 1

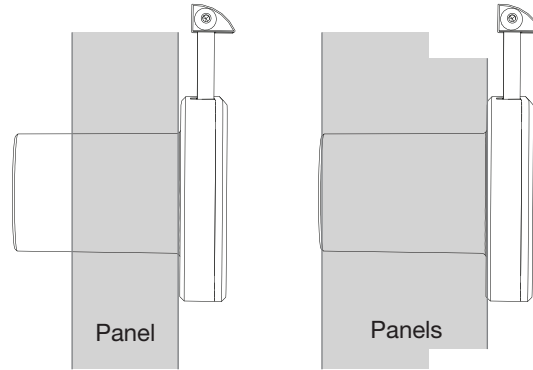

Recessed Installation (Panel must be routed)

Refer to Page 3

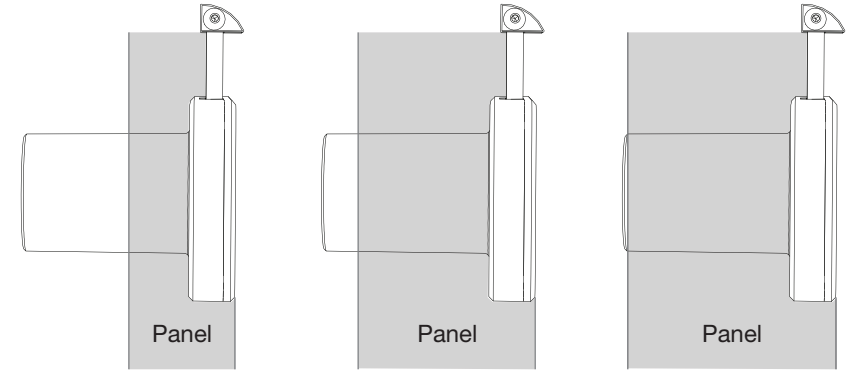

SD0319 Rev0 01/19/16

Replace a non-recessed lock PAGE 1
Replace a recessed lock PAGE 3
New installation PAGE 5

www.invue.com
NA / LATAM // 704.752.6513 • 888.55.INVUE
EMEA // +31.23.8900150
APAC // +852.3127.6811

1 Replace a non-recessed lock:
Mark the centerline on inside and outside of fixture.

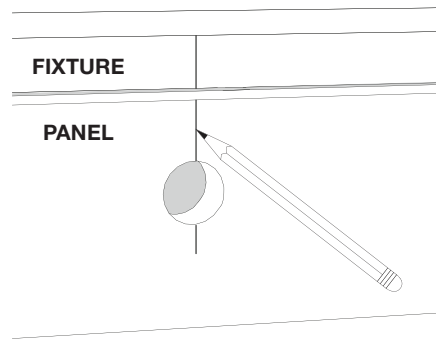

2 Align existing hole, centerline, and top of panel with markings on lock drill template. Determine which lock will be installed (PL701 or PL702).

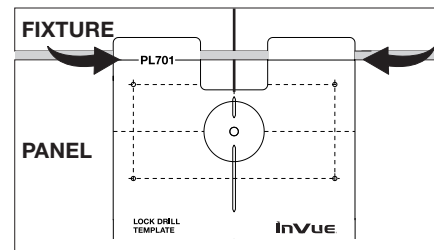

OR

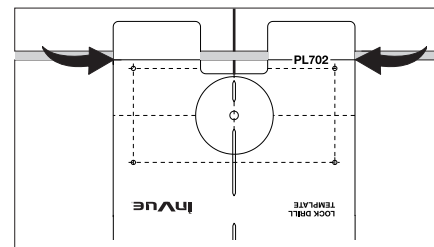

3 Pre-drill as necessary and use screws provided. Use screwdriver to screw lock to panel. **Note:** Do not use power tools for this procedure.

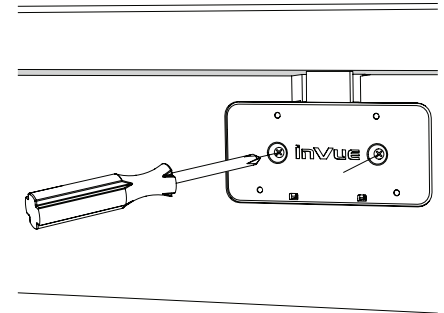

- 4** Insert strike plate drill template onto latch of lock.

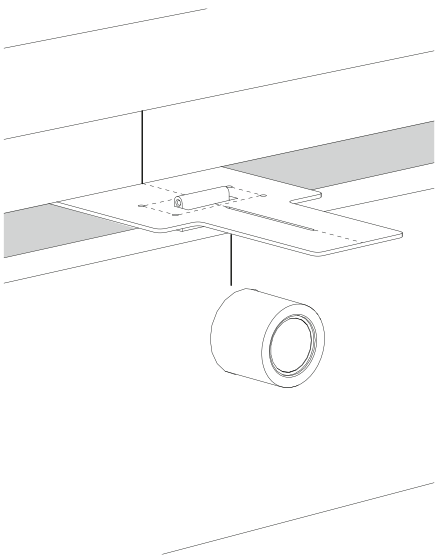

- 5** Close panel and confirm template is straight. Mark position on template.

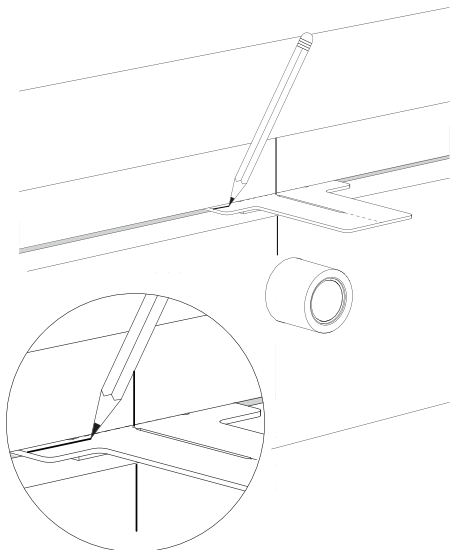

- 6** Move panel away from fixture. Align mark on template with inside ledge of fixture. Align centerline and tape template in place.

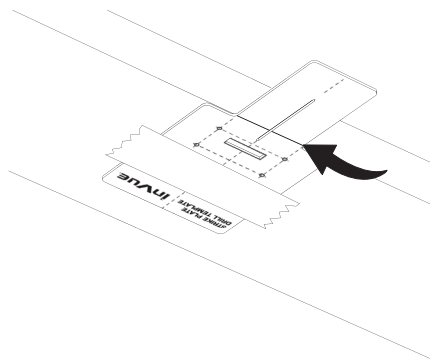

- 7** Mark four corners and remove template. Connect dots to create outline for strike plate.

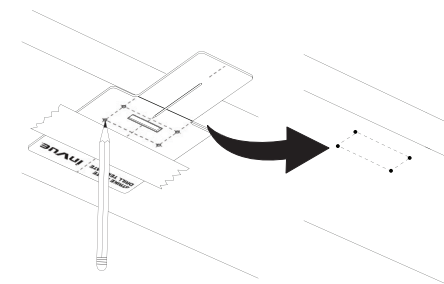

- 8** Use a maximum 4 mm (0.16") bit to route area for strike plate to at least 6 mm (0.24") deep.

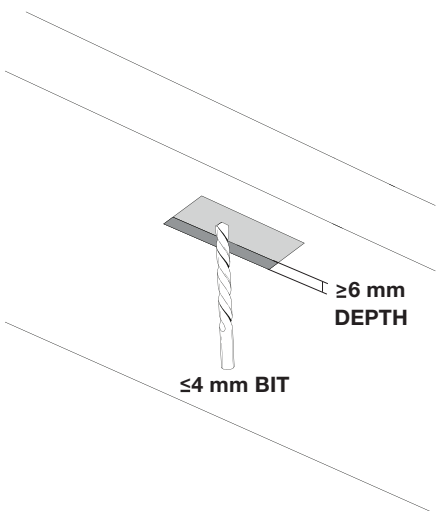

- 9** **Optional shim installation:** Gap between panel and fixture should be between 3 mm and 5 mm (0.12" and 0.2"). If gap is too large, install shims with strike plate.

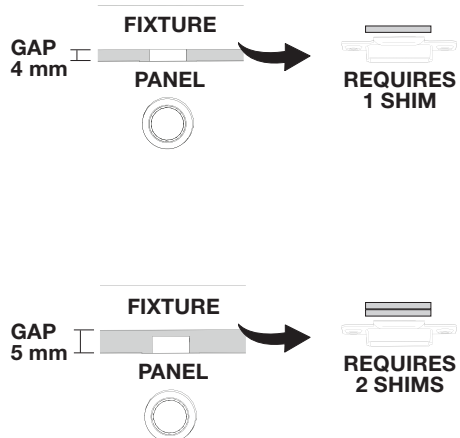

- 10** Screw strike plate to fixture. Pre-drill as necessary and use fasteners provided. **Note:** Chamfer holes 1 mm (0.04") if shims are not used.

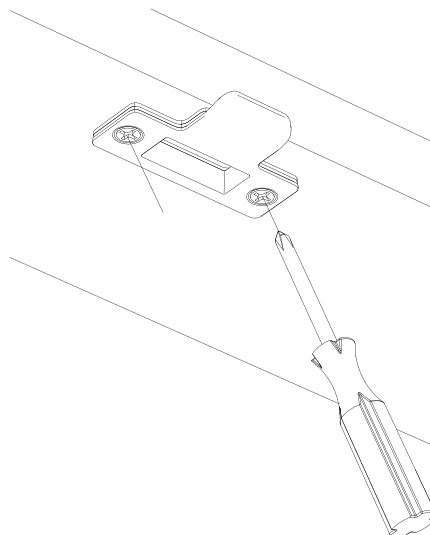

- 11** Position ramp on latch to slide along curve of strike plate. Screw ramp to latch.

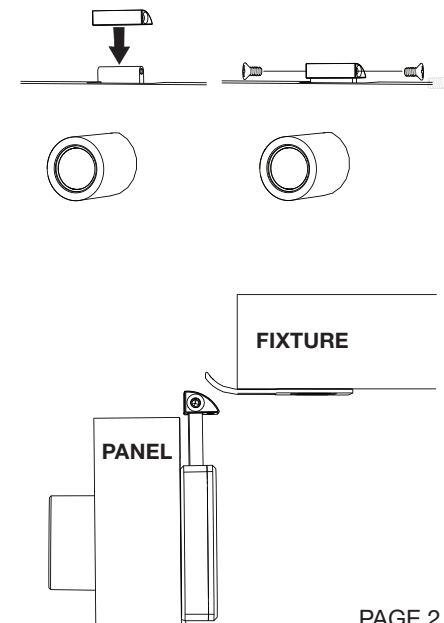

- 1 Replace a recessed lock:**
Mark the centerline on inside and outside of fixture.

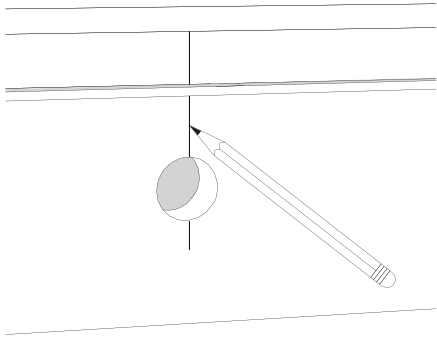

- 2** Align existing hole, centerline, and top of panel with markings on lock drill template. Determine which lock will be installed (PL701 or PL702).

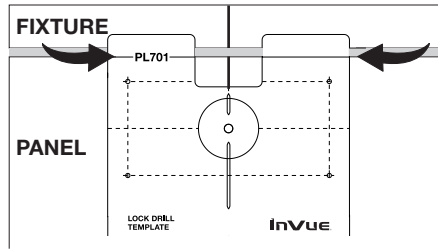

OR

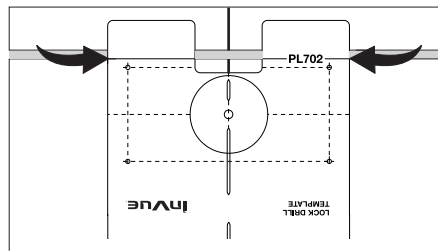

- 3** **On back of panel:** Use template to mark corners. Trace template cutout for latch. Connect to create outline for lock body.

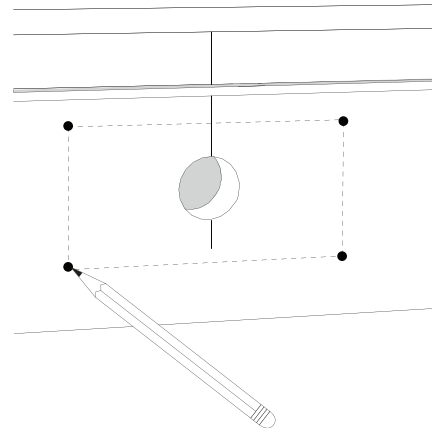

- 4** Confirm hole is 22 mm (7/8"). Chamfer 1 mm (0.04").

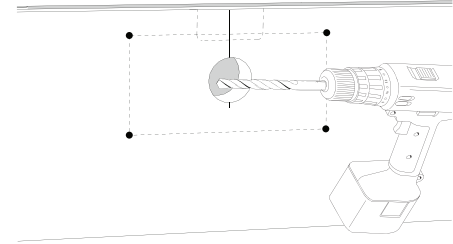

- 5** Use a maximum 4 mm (0.16") diameter bit to route area for latch to 10 mm (0.4") deep.

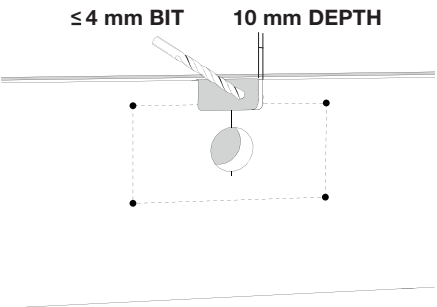

- 6** Use a maximum 10 mm (0.4") diameter bit to route area for body to 8 mm (0.3") deep.

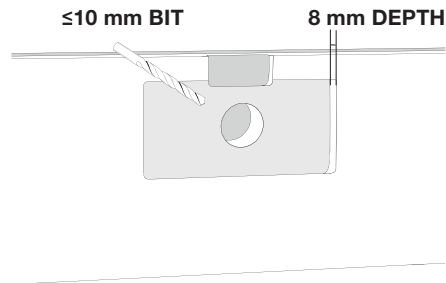

- 7** Pre-drill as necessary and use fasteners provided. Use screwdriver to screw lock to panel. **Note:** Do not use power tools for this procedure.

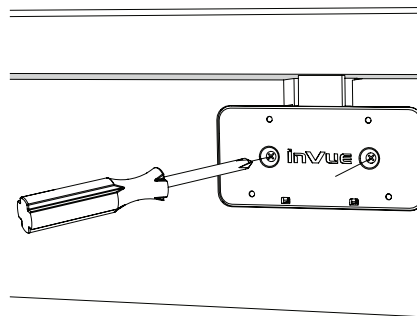

- 8** Insert strike plate drill template onto latch of lock.

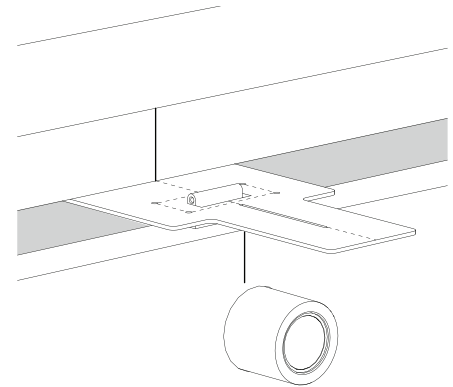

- 9** Close panel and confirm template is straight. Mark position on template.

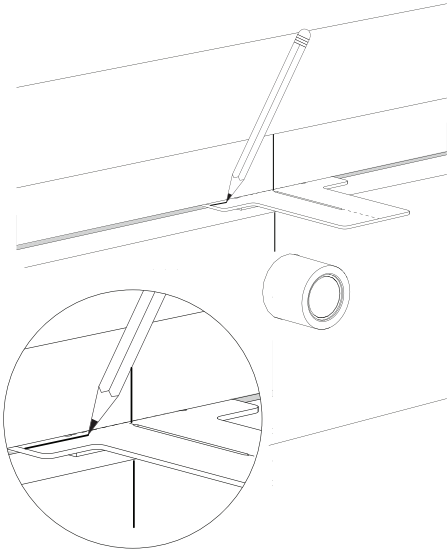

- 10** Move panel away from fixture. Align mark on template with inside ledge of fixture. Align centerline and tape template in place.

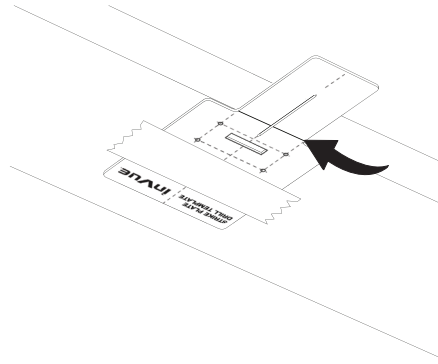

- 11** Mark four corners and remove template. Connect dots to create outline for strike plate.

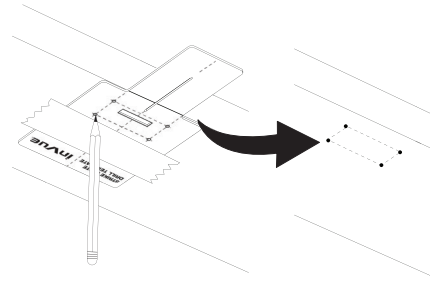

- 12** Use a maximum 4 mm (0.16") bit to route area for strike plate to at least 6 mm (0.24") deep.

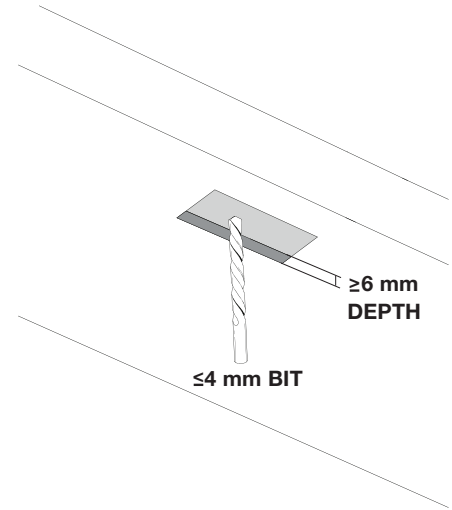

- 13** **Optional shim installation:** Gap between panel and fixture should be between 3 mm and 5 mm (0.12" and 0.2"). If gap is too large, install shims with strike plate.

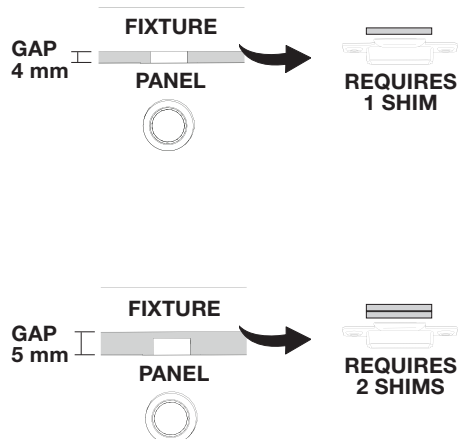

- 14** Screw strike plate to fixture. Pre-drill as necessary and use fasteners provided. **Note:** Chamfer holes 1 mm (0.04") if shims are not used.

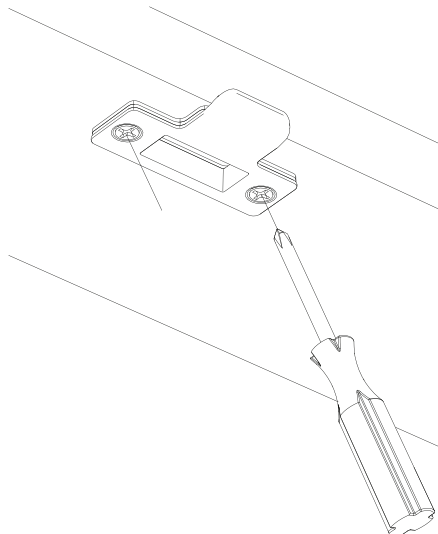

- 15** Position ramp on latch to slide along curve of strike plate. Screw ramp to latch.

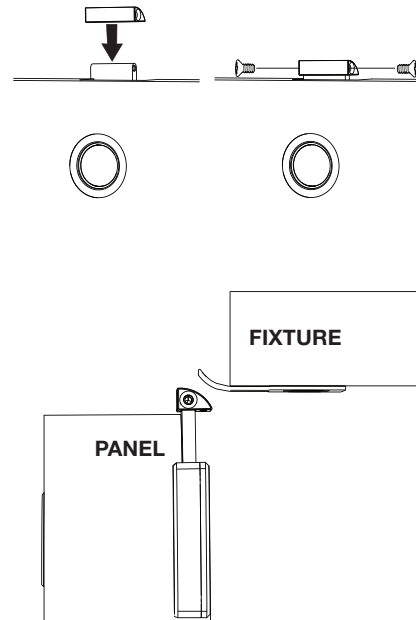

- 1 New installation:** Mark a centerline on fixture and 20 mm (0.75") thick panel with desired location of lock. Mark centerline on inside of panel.

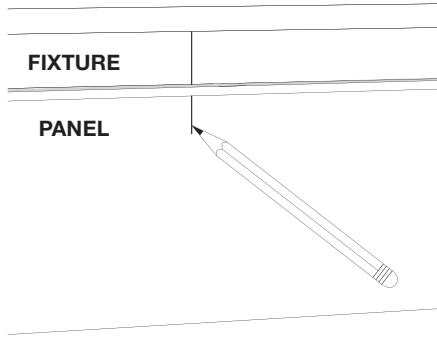

- 2** Determine which lock will be installed (PL701 or PL702). Align lock drill template with top of panel and centerline.

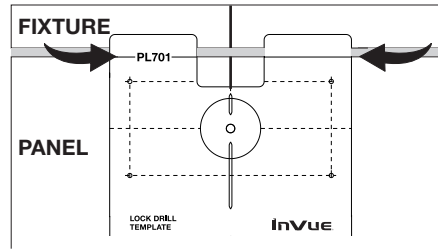

OR

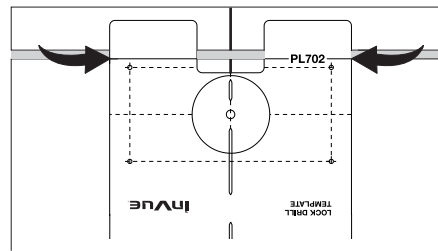

- 3 Inside panel:** Mark center hole for nose of lock.

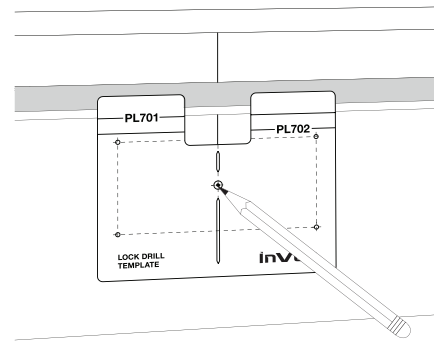

- 4** Use template to mark four corners. Connect to create outline for lock body.

If not recessing lock, skip to step 8.

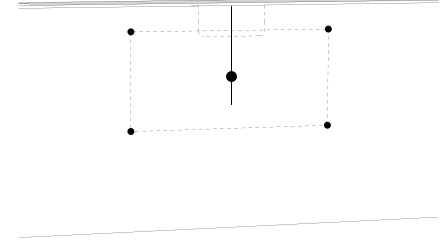

- 5** Drill a pilot hole to 3 mm (1/8") and finish to 22 mm (7/8"). Chamfer 1 mm (0.04").

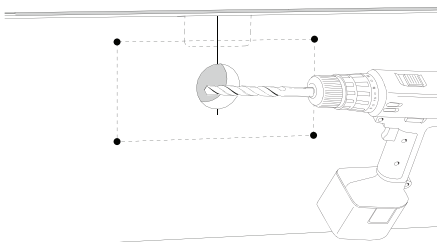

- 6** Use a maximum 4 mm (0.16") diameter bit to route area for latch to 10 mm (0.4") deep.

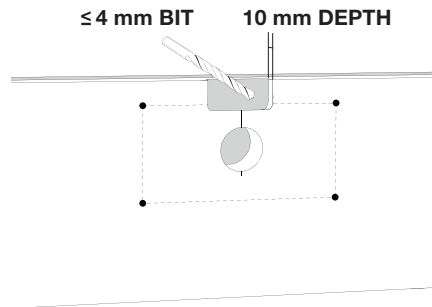

- 7** Use a maximum 10 mm (0.4") diameter bit to route area for body to 8 mm (0.3") deep.

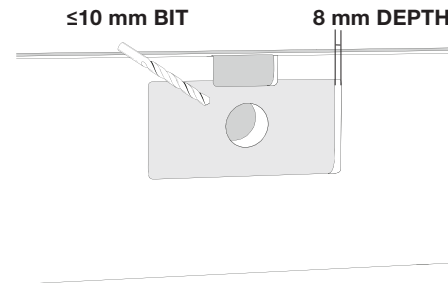

- 8** Pre-drill as necessary and use fasteners provided. Use screwdriver to screw lock to panel. **Note:** Do not use power tools for this procedure.

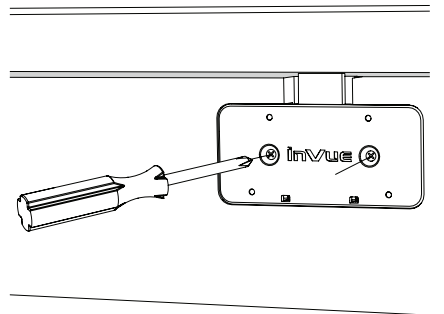

9 Insert strike plate drill template onto latch of lock.

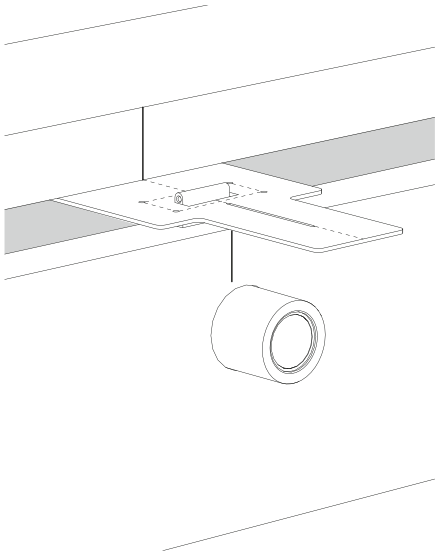

10 Close panel and confirm template is straight. Mark position on template.

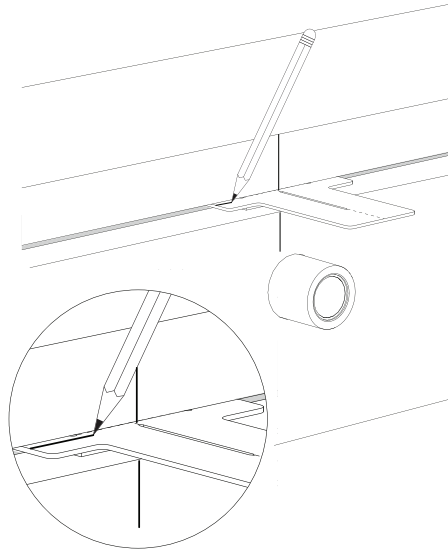

11 Move panel away from fixture. Align mark on template with inside ledge of fixture. Align centerline and tape template in place.

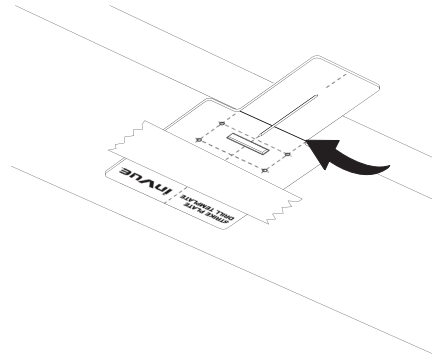

12 Mark four corners and remove template. Connect dots to create outline for strike plate.

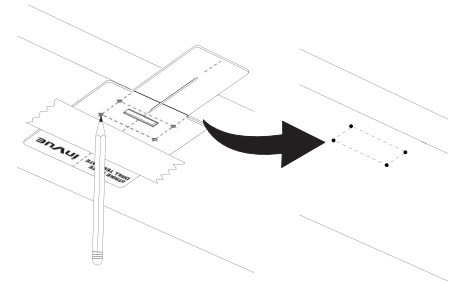

13 Use a maximum 4 mm (0.16") bit to route area for strike plate to at least 6 mm (0.24") deep.

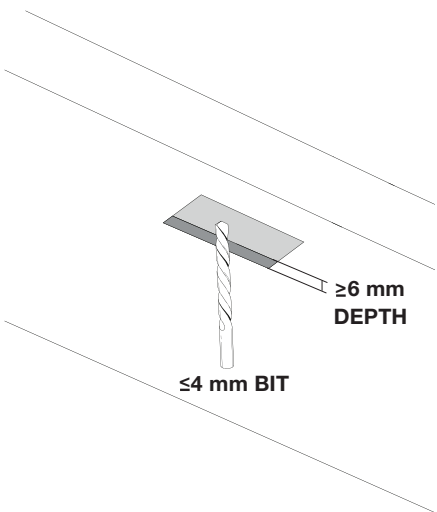

14 **Optional shim installation:** Gap between panel and fixture should be between 3 mm and 5 mm (0.12" and 0.2"). If gap is too large, install shims with strike plate.

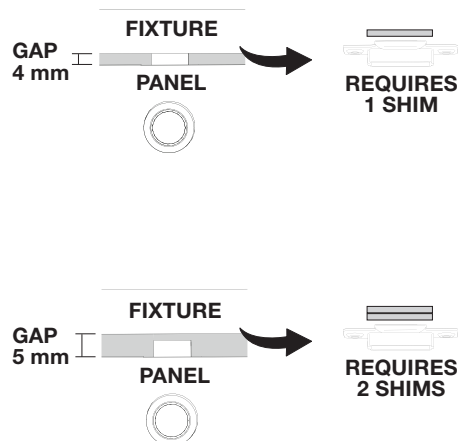

15 Screw strike plate to fixture. Pre-drill as necessary and use fasteners provided. **Note:** Chamfer holes 1 mm (0.04") if shims are not used.

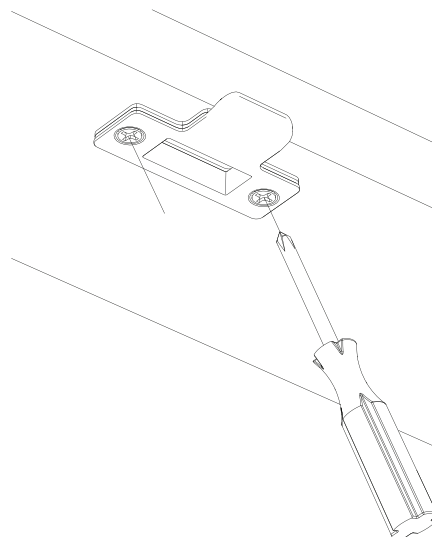

16 Position ramp on latch to slide along curve of strike plate. Screw ramp to latch.

